

SCHIEDERWERK

**Ignitor
for electronic lamp ballasts**

HZG 15-Series

Technical Specifications

CHARACTERISTICS

Maximum lamp current	15 A
Frequency (square wave)	200 .. 400 Hz
Voltage range	150 V - 380 Vpp
Maximum ambient temperature	60° C
Weight	ca. 0,370 kg
Maximum lamp current	15 A

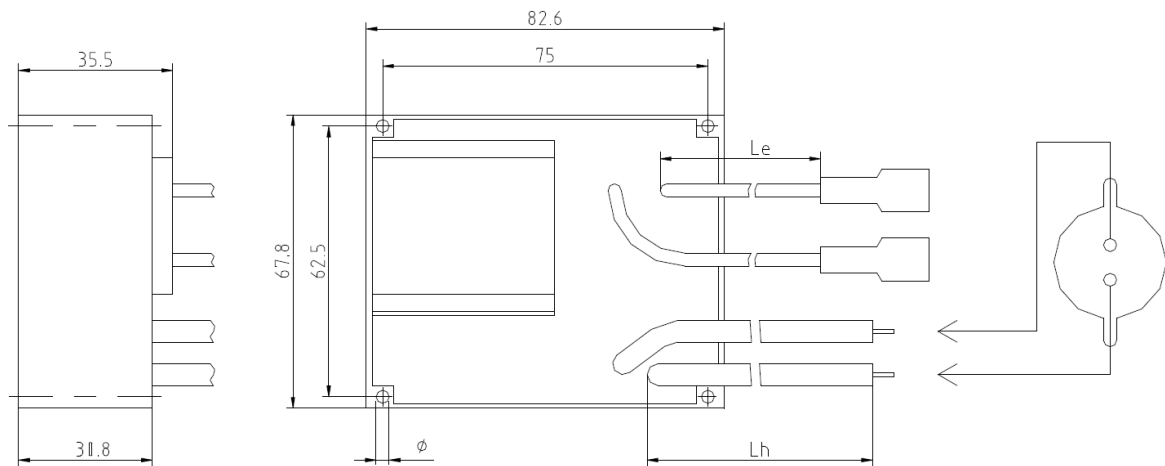

ORDER NUMBERS

Article	Order No.	Le	Lh	Ø	Ignition Voltage
HZG 15-25	32 119 1000	600	260	3,2	25 kV
HZG 15-30/2	31 021 1000	600	880	3	25 kV

Attention:

These Ignitors are developed for Schiederwerk electronic ballasts, only. Using them with non-Schiederwerk ballasts will void warranty claims.

Hot restrike ignitors have to be used with electronic ballasts having limited ignition time. Hot restrike ignitors should not be operated continuously for more than 3 seconds, otherwise dysfunction could be caused.

Cold start ignitors have to be used with electronic ballasts having limited ignition time. Cold start ignitors should not operate continuously, otherwise dysfunction could be caused.

Warning Notice

Do not attempt to handle or operate an electronic power supply (EPS) and ignitor before completely reading and understanding this notice. Contact Schiederwerk if you are uncertain of hazards associated with these devices.

The ignitor produces starting voltages of up to 60 kV and electromagnetic radiation interference which are hazardous to personnel and sensitive instrumentation. Exercise appropriate care in the handling of high voltages. Do not touch any conductive parts during operation.

Ensure the units are disconnected from the mains before exchanging the lamp connected to the PSU / ignitor resp. to the end application. The residual charge left on the capacitors is a danger to life if the units are still connected to mains!

Caution: The residual charge on the capacitors can be a danger to life even if the units are disconnected from the mains. Please handle with care!

Both electronic lamp ballast and ignitor must never be installed or operated in an explosive or volatile atmosphere. Never use the ballast or ignitor near flammable gases or liquids. See that there will be no moisture, dust or similar which could lead to short circuits or fire.

Before using the ballast or ignitor in any kind of outdoor application you have to take additional measures and observe special requirements. If you are uncertain, contact Schiederwerk. No potential isolation is provided between line input and output. Accidentally grounding of an output terminal by direct contact or arcing to GND can damage the unit (no warranty replacement).

The unit is designed for case mounting. Due observation of electrical safety and RFI suppression code requirements is mandatory in all applications. See that sufficient cooling of EPS and ignitor is provided.

All installation and repair work on this unit is only permitted by qualified personnel. Always comply with local safety requirements when operating the unit uncased.

Extreme care must be taken when testing the unit live. The use of an isolating transformer is mandatory. On no account may grounded test instruments / meters be used for this purpose!

Schiederwerk does not assume liability for disregarding of this notice, incorrect use of the EPS and ignitor or dis-regarding of any legal requirements. This product is subject to technical changes without prior notice.

CAUTION:

**Mains supply must be fused according to local safety regulations.
Schiederwerk recommends 2 pole fuse (L+N). The appropriate fuse value can be calculated as:**

$I_{\text{fuse}} \geq 1,85 \times P_{\text{lamp}} / U_{\text{line}}$

Last Update: 30.03.2016